

Operation Manual and Technical Specification

RPP-A***WLAN radon probe*****1 Meet**

Probe is designed for continuous measuring of radon concentrations in buildings.

Portable probe basis is a measuring chamber with a semiconductor photodetector. Radon enters the chamber by diffusion through the input filter on the bottom of probe. The probe measures in autonomous and time continuous way (continual monitor). The probe saves time records of these radon concentration values including values of humidity and temperature within its internal memory (typically at an interval of 1 hour). Next saved value is time record of measuring energy spectrum (typically at an interval of 12 hours). The probe is random for location in measured place, but generally it is put on the bottom of the probe. Bottom of the probe cannot be covered. The probe can be switched ON/OFF by switch. LEDs „STAT“ and „CHRG“ indicate current status of probe see 'Operation manual' below. Waterproof cover for electronics (IP67).

The resulting values can be downloaded continuously during measurement or at once at the end of measurement. Data from the radon probe can be downloaded to a PC directly via USB interface or wirelessly via antenna and Central Unit. Central Unit is not included with package of probe and it is sold and delivered extra .

Radon Probe can be operated by these ways:

- A) **Standalone probe** - Thanks to its independent battery power, portable radon measuring probe supports flexible placing options within monitored structures. Accumulator will last for more than 1 year after full charging. After switching on probe immediately starts measuring and saving results into internal memory. The resulting values are downloaded after end of the measurement by B) or C) way.



- B) **Probe connected via USB** – Using RADONreader app and USB cable is possible to download results to PC continuously during measurement or at once at the end of measurement. RADONreader application, drivers and user manual is free downloaded on producer website.

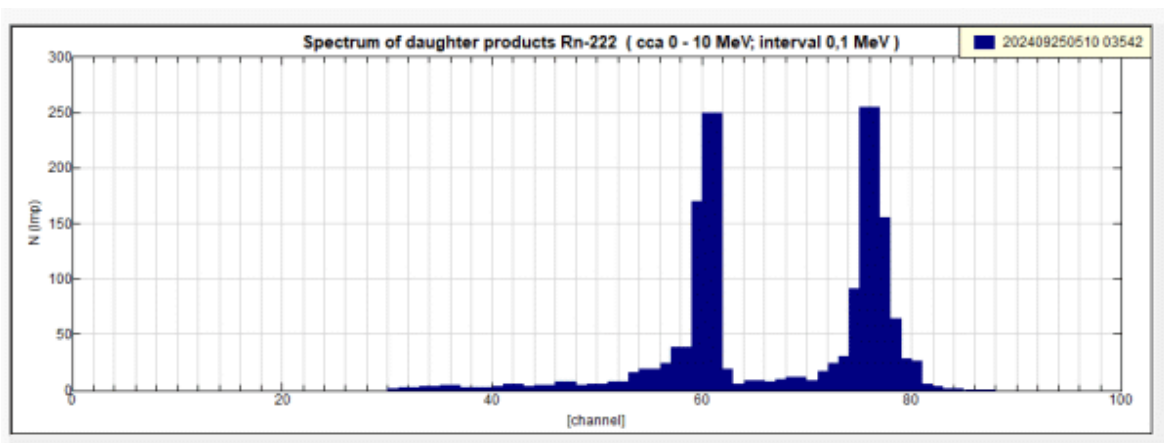
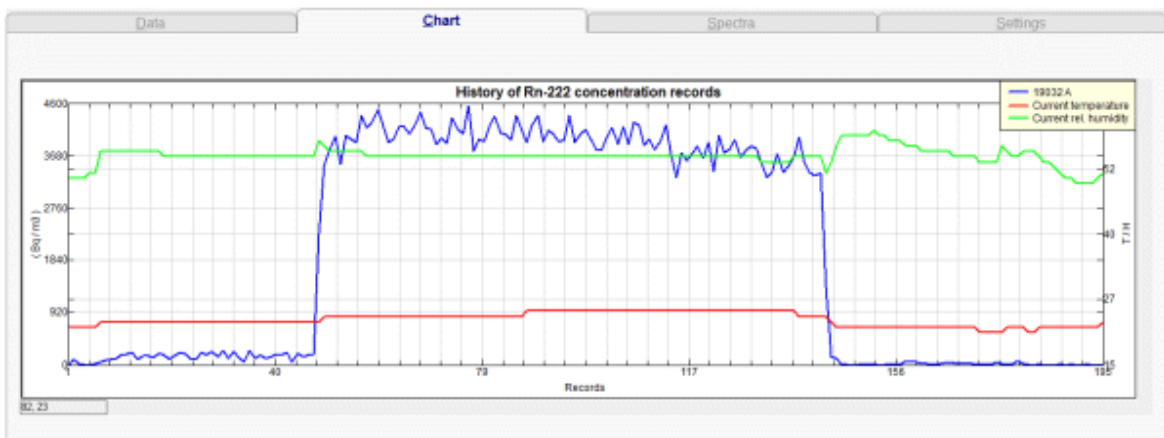
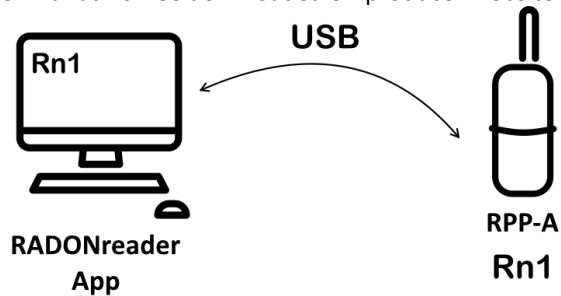

- C1) **Wireless network for radon measurement** - Central Unit supports simultaneous data downloads from up to 16 probes. All values are saved again into central unit memory. Via connected computer to Central Unit and TERAview application on PC it is possible to download and process all data from system and configure whole system. Setting and configuration of Radon Probe and whole system is also managed by TERAview application on PC. TERAview application version 3.11.6 and higher, drivers and user manual with detail configuration description is free available at producer.

In case of time continuous measurement of radon concentration or in case of setting in regulation system the probe must be placed in radio range of Central Unit. Distance (radio range) between probe and central unit is up to 600m in open space. In buildings it depends on number of walls, building material, etc. Strength of radio signals (RSSI) is monitored by Central Unit. If radio signal strength between individual elements is insufficient, radon probe must be inserted or repeater must be used to extend the signal;

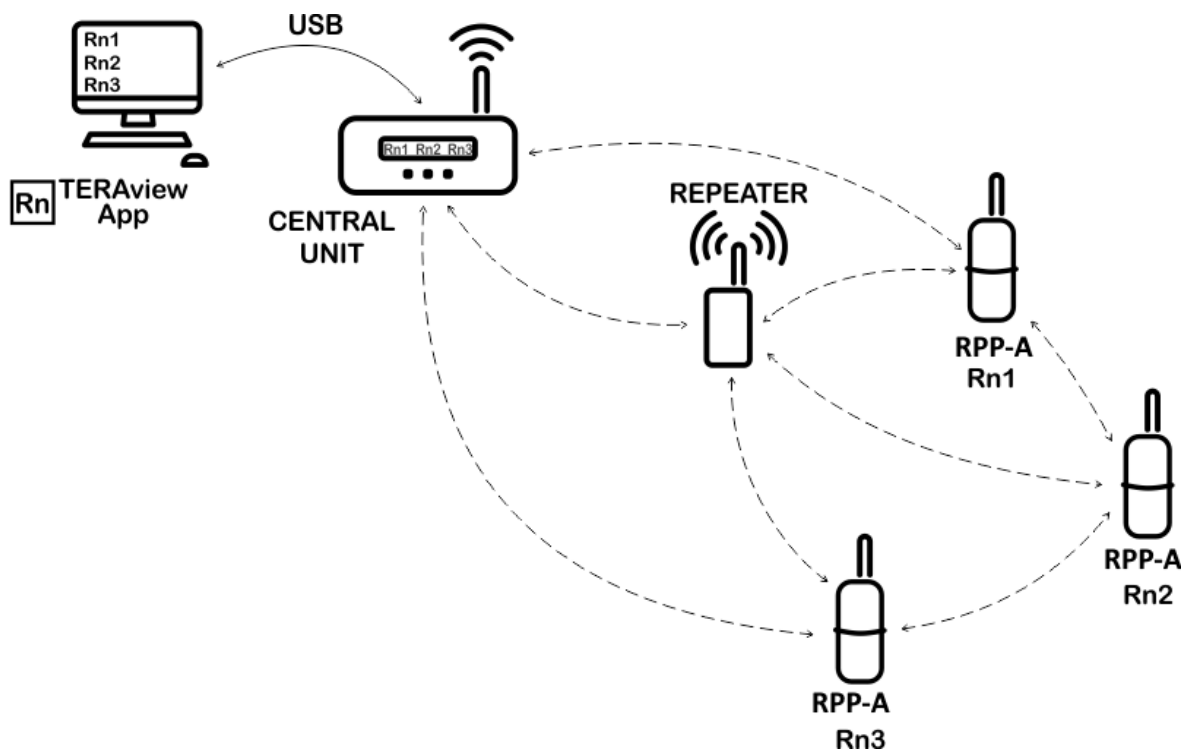

- C2) **Wireless network for radon regulation** – Features of system are same as in C1) way. Radon measuring probes located in building transmit their current radon concentration values to central unit wirelessly. Central unit analyzes this information and on the basis of measured (set) concentration level value it sends command to actuator (wireless actuator or actuator in central unit can be use) which is hardwired with power relay. Power relay switches on a fan which decreases radon concentration within an area. After decreasing of radon concentration, actuator receives command to switch off fan. This cycle repeats depending on increasing or decreasing volume activity of radon in building.

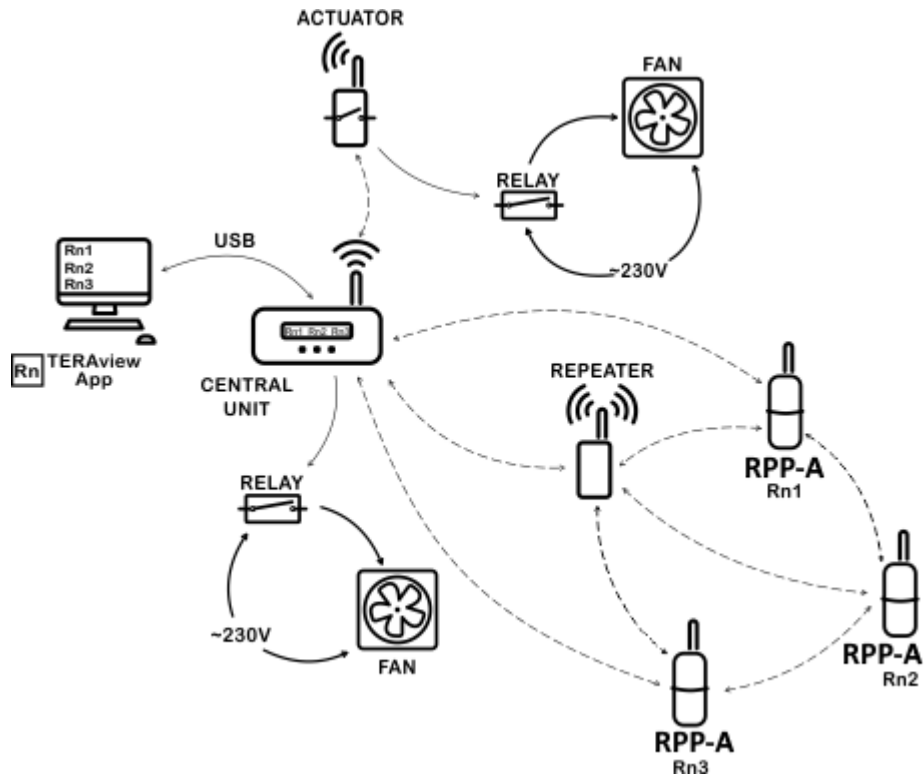

2 You get

- WLAN Wireless Radon Probe
- Power adapter 230VAC/5VDC
- USB cable A-B
- Antenna
- Operation Manual

3 Product Specification

Product	WLAN Wireless Radon Probe
Type symbol	RPP-A
Average measurement sensitivity	0,25 count/hour/Bq.m-3 (method RaA+RaC; 15°C ÷ 30°C; rel. hum. 20% ÷ 40%)
Measuring range	MDA – 100 000 Bq/m ³ ; špičkově až 10 MBq/m ³ MDA = 100 Bq/m ³ per 1 hour or 20 Bq/m ³ per 24 hours
Measurement uncertainty	< 13% at 300 Bq/m ³ per 1 hour; < 3% at 300 Bq/m ³ per 24 hours
Measuring chamber capacity	0,176 dm ³
Response rate	< 30 minutes (RaA); < 3 hours (RaA + RaC)
Radon records	calculated from RaA (quicker, less sensitive) calculated from RaA + RaC (slower, more sensitive)
Measuring relative humidity range	0 – 100 %
Measuring temperature range	-40 to + 125 °C
Radio interface	868MHz
Max number of measuring network elements	16
Probe to terminal unit RF range	depends on number of walls and building material, up to 600 m in open space
Possibility of using repeater	yes
Records saving interval	1- 255 minutes, default 1 hour
Results memory capacity	5000 records (208 days of 1 hours records), spectra 300 records
Powering	internal rechargeable accumulator; charging via USB
Accu life after full charging	>1 year (also depends on operating conditions)
Current radon concentration	short-term (0,5 hour running average from RaA + RaC) long-term (24 hours running average from RaA + RaC)
Dimension	Ø 80 x 175 mm
Waterproof	IP67 (only for electronics)
Operating conditions	Temperature: -10 ° C to +40 ° C Recommended relative humidity: 10% - 75% Maximum working relative humidity: 0% - 99% * Increased humidity reduces the life of a charged battery. * There must be no condensation of water in the chamber - erroneous results
Detector life	50-100 million pulses; that means at an average concentration of 1000 Bq / m ³ -> 12 years; 10 000 Bq / m ³ -> 1 year

4 I work like this

Switching on and off:

The probe measures radon concentration autonomously and communicates in wireless network only if the switch is in position „on“. The switching on is signaled by LED diode „STAT“ according chart below.

If the switch is in position „OFF“ the probe doesn't measure radon concentration and doesn't communicate in wireless network. In switching off mode the probe only keeps running real time for correct date and time of records in case of switch it on again. By switching off the probe doesn't lose previous records of measurement. The switching on is signaled by LED diode „STAT“ according chart below.

It is possible to download data from probe over USB in both position of switch.

LED diode „STAT“:

It signalizes status radon probe according to following chart:

Color	Description
Green blink 3x	Radon probe has just been turned on.
Green blink after 8s	Radon probe measures and works correctly
Yellow blink 4x	Radon probe has just been turned off.
Green / Yellow blink after 5s	Radon probe measures but troubles are occur. – especially low capacity of accumulator. Warnings and errors are shown in PC application.
No light, No blinking	Radon probe doesn't measure or accumulator is empty or device is damaged. Charging process of accumulator is described in chapter „Basic Maintenance/ Accumulator charging“

Antenna installation:

Supplied antenna is screwed on antenna connector. When installing antenna, hold antenna by knurled end.

Power supply:

According to operation method the radon probe can be supplied:

- 1) By internal accumulator for portable use – Radon probe includes internal accumulator which is able to ensure autonomous operation of probe for more than 12 months without charging. Depends on frequency of wireless data downloading from probe and depends on climatic condition of probe use. Accumulator is charged over USB port and over provided USB cable. The USB cable is possible to connect to PC or to delivered power adapter. Status of accumulator and charging process are described in paragraph 'Basic Maintenance/Accumulator charging'
- 2) By mains power supply 230V/50Hz for stationary use – Radon probe is permanently supplied by delivered power adapter. Power adapter is connected to probe via provided USB cable. In case of blackout internal accumulator ensures UPS function.

Configuration:

Setting and configuration is different according to operation way of radon probe.

If the probe is used for autonomous measurement and data downloading via USB interface then the setting and configuration are realized by RADONreader application. RADONreader application, drivers and user manual with detail configuration description are free downloaded on producer website.

If the probe is used for wireless measurement and wireless data downloading then setting and configuration of probe and whole measuring system is realized by Central Unit connected to PC and TERAvue application. Central Unit is not included with package of probe and it is sold and delivered extra. TERAvue application, drivers and user manual with detail configuration description are free available at producer. For successful probe configuration in measuring system is essential to know probe radio channel number (communication wireless channel) and P2P address (identification in wireless net). Both parameters are printed out on probe serial number plate. Probe radio channel number is possible to change by TERAvue application and it must be identical to central unit radio channel number. P2P address is permanent and it can occur in one big wireless net only once. Only Central Unit P2P address can be identical to P2P address of other elements in network.

5 Basic Maintenance

Accumulator charging:

During portable use of radon probe is essential to monitor state of internal accumulator and recharge it if necessary. If accumulator is discharged the probe automatically turns off. The probe is switched on again powering USB port.

Current state of accumulator can be determined by these ways:

1) By LED diode 'STAT' - If LED starts blinking in green-yellow color it indicates that system is working incorrectly and one of main case is low voltage of accumulator. (see paragraph "Operation Manual / LED diode "STAT"")

2) In TERAview and RADONreader application - where you can check current accumulator voltage.

Voltage should not fall below 3.5 V, in limit conditions falls below 3.3V.

Accumulator is charged via USB port using supplied USB cable. USB cable can be connected to PC or to supplied power adapter. Connect USB cable with power to USB port of probe. LED diode 'CHRG' next to USB port of probe indicates charging status according to following chart:

LED diode 'CHRG'

Color	Description
Green	Accumulator is fully charged
Yellow	Accumulator is being charged
Green - Yellow alternate blinking	Accumulator is damaged, contact Service Center
No light, No blinking	It is not connected to an external power supply or device is damaged.

Accumulator is fully charged when LED diode 'CHRG' is green. You can disconnect USB cable.

Recalibration:

We recommend regular recalibration of the device at the manufacturer within 1-2 years.

Within the warranty period, one recalibration is free from the manufacturer.

6 Repairs

Any repairs and non basic maintenance must be performed exclusively by producer Piketronic s.r.o..

7 Warranty

- This product is covered by warranty of 24 months from purchase date.
- In case of warranty claim, please contact our Service Department.
- Warranty covers any defects in materials or workmanship and excludes any damage resulting from or caused by transport or handling or by any misuse.
- Warranty ceases if product has been used improperly or its seal is broken.
- In case of warranty claim, warranty period is prolonged by number of days product was undergoing warranty repairs.
- After the end of its life, product must be handled as e-waste.

8 Accessories

Radon Probe accessories are available at producer or at distributor.

Probe holder



Reserve antenna



Transport waterproof case for 4 probes



Outdoor cover with solar powering

